



Welcome to the Real Flame family of gel fuel products. If you have questions please call customer service at 1-800-654-1704 or log on to www.REALFLAME.com

⚠️ WARNINGS ⚠️



1. Fireplace is designed to be used with Real Flame® gel fuel only. Do not use with any other gel fuel or any other flammable liquid or gel.
2. Read entire label and instructions before using Real Flame gel fuel.
3. Make sure fireplace is set on a flat, level and stable surface. Keep fireplace stable at all times.
4. Make sure fireplace and gel fuel are burned on a flat and level surface.
5. Never leave a burning fire unattended, especially around children or pets.
6. Fireplace is not to be operated by children. Keep away from children and pets.
7. Exercise the same precautions as you would with any open fire.
8. When in use some surfaces will be hot, use caution.
9. Never touch logs, gel fuel cans or any other metal surfaces during or immediately after burning gel fuel. They will be extremely HOT. Allow them to cool for 60 minutes before touching.
10. Do not burn more than three cans of fuel at once.
11. Do not place more than 15 lbs. of weight on the top of the fireplace at anytime.
12. Do not alter fireplace, metal firebox or log set in any manner.
13. Keep fireplace and gel fuel cans away from flammable materials at all times.
14. Do not store or use gasoline or any other flammable vapors, liquids, or materials in the vicinity of fireplace and gel fuel.
15. Do not wear flammable or loose clothing when operating the fireplace.
16. Do not move fireplace while in use. Do not attempt to move or store the fireplace until 60 minutes after gel fuel cans have been extinguished.
17. Do not burn trash, paper, or wood in the fireplace. Burn only Real Flame® gel fuel in the fireplace.
18. Do not burn gel fuel outside designated burn areas on the metal grate.
19. Do not put fireplace in an area with lots of traffic, such as a hallway or entryway.
20. In case of an emergency use a CO2 extinguisher to extinguish the fire.
21. Death, serious injury or damage to property may occur if the warnings above are not followed.
22. If for any reason you cannot follow these warnings please call us at 1-800-654-1704.

NOTICE: Buyer assumes all responsibility for safety and use that is not in accordance with instructions and warnings.

Using your Fireplace

- Fireplace is designed to be used indoors, there is no need for ventilation.
- Use extreme caution while burning. Some surfaces become extremely hot during use.
- Follow all instructions included with gel fuel before use.
- Before using fireplace, be sure you have read and understand the step-by-step instructions.
- During the initial burn you may experience a slight odor. Odor is temporary and will be absent on following burns.

Model # L7400
Berkshire Fireplace

Step One

Parts List

Number	Description	Part Number	Quantity
1	Base	7401	1
2	Left Side Panel	7402	1
3	Right Side Panel	7403	1
4	Left Trim Panel	7404	1
5	Right Trim Panel	7405	1
6	Center Panel	7406	1
7	Mantel Top	7407	1
Not Shown:			
	Firebox Clips	1075	2
	Screws	9716	Bag

- Set base (1) on a flat surface.
- Using tongue and groove fit the Right Side Panel (3) into the Right Trim Panel (5). Make sure the top edges of the Right Side Panel and Right Trim Panel are flush. Attach together with 3 screws through mounting blocks
- Repeat with Left Side Panel (2) and Left Trim Panel (4).
- Place assembled Right Panels on base with mounting block on bottom of Right Side Panel (3) against inside of base as shown in figure 1. Attach with 3 screws.
- Repeat process using Left Side Panels.

Before assembly, locate instructions and hardware. Take out all parts and compare them to the photograph and the assembly illustrations. Be sure you have all parts identified.

Check for screws that are wrapped in the packaging to be sure you don't discard them. You may have extra screws.

A helping hand is always good. Assemble fireplace with an adult assistant if possible.

The cement log is heavy. Put the fireplace in the desired location before inserting cement log.

Use caution not to over tighten screws.

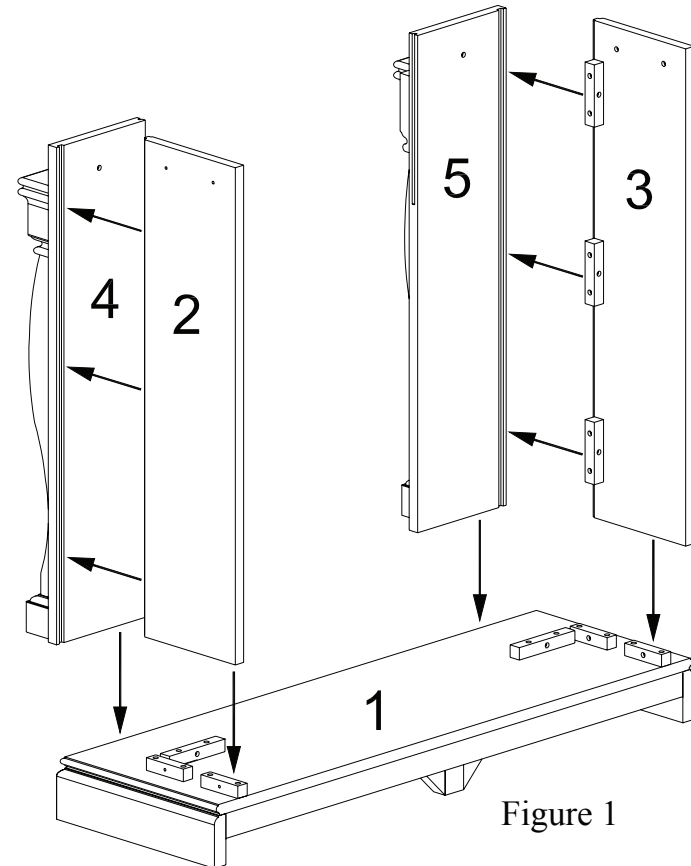

Figure 1

Step Two

- Slide the Center Panel (6) between Right and Left Trim Panels so the top edge of Center Panel is flush with the top edge of the Right and Left Trim Panels. Attach to rear of Front Panels with 6 screws.

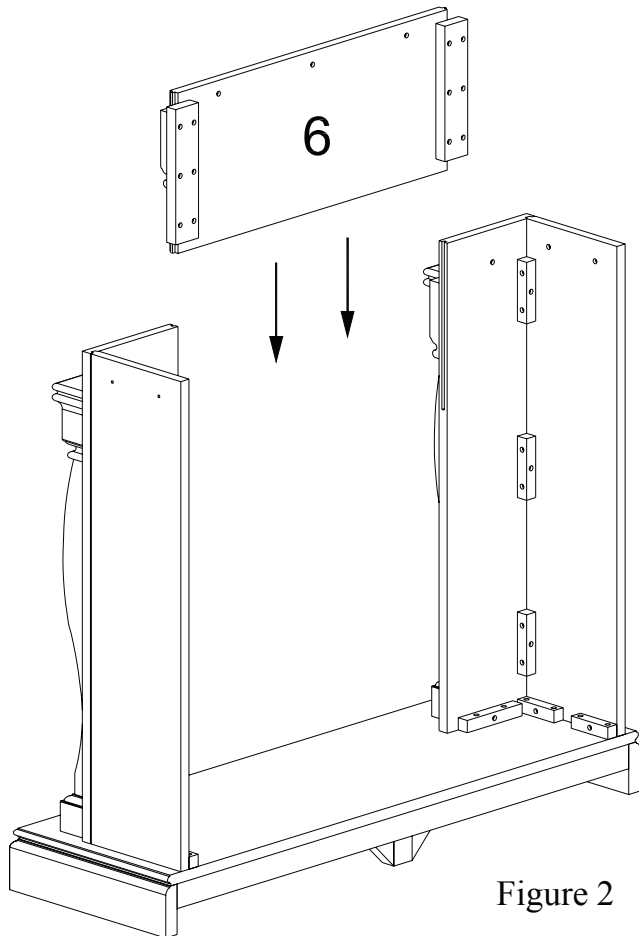

Figure 2

Step Three

- Set Mantel Top (7) on top of unit so trim hangs over the front and sides.
- First attach through the holes in the center panel and front panels then through the holes in each side panel.

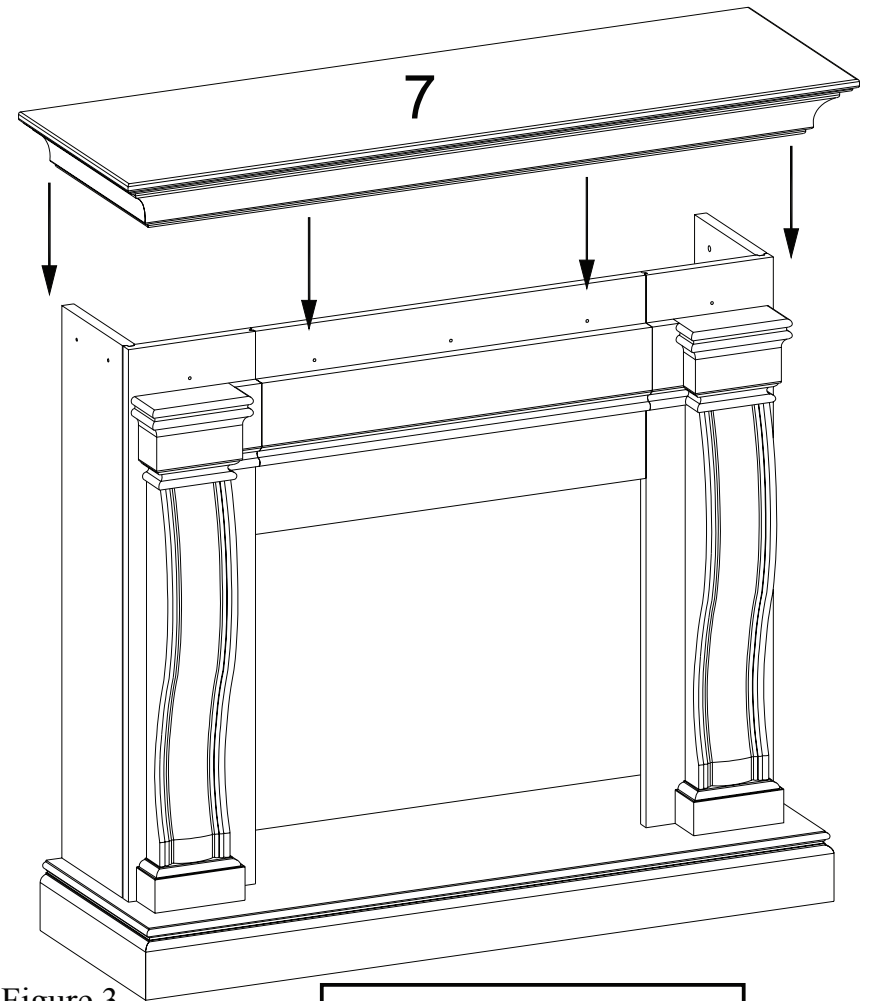

Figure 3

You are now ready for the firebox installation. Please refer to the instructions that are included with your firebox.

Care and Cleaning

Dust the mantel periodically.

Using a soft cloth and a wood cleaner, wipe the mantel clean in the direction of the grain to minimize the appearance of scratches and scuffs in the finish.

Do not use water to clean mantel. Water may cause swelling, warping or stains if allowed to penetrate the finish of the mantel. Use protective pads or cloths whenever possible.

Avoid placing mantel in rooms with lots of humidity or where humidity could be a problem. This may cause warping to the mantel.

Avoid direct sunlight if possible to reduce the possibility of bleaching the finish. If direct sunlight cannot be avoided, the mantel should be placed so that sunlight hits the mantel evenly so sunlight bleaching is even and consistent.

Warranty & Return Policies

Ninety-Day Warranty: The Jensen Company warrants Real Flame® vent-less fireplaces and accessories to be free from defects in parts and workmanship under normal use and service for a period of 90 days from date of shipment. In the event of such defect in parts or workmanship, Jensen will, at its option, replace the defective product or refund the purchase price to the extent of the defective product's replacement cost. The foregoing is the exclusive remedy and The Jensen Company disclaims all other warranties, including any implied warranty of merchantability or fitness for a particular purpose. In addition, The Jensen Company will not be responsible for consequential damages in excess of the purchase price of the product on which such liability is based.

Replacement Parts: Replacement parts are available for most units. Occasionally, parts may arrive damaged due to mishandling during shipping. If you are in need of a replacement part, please contact our customer service department with the fireplace model number and part number needed. We will ship out a replacement part due to shipping damage at no charge.

Returns: Please inspect all items immediately after receiving. We hope you will be completely happy with your purchase. If you find within 15 days of receipt of your product that you do not wish to keep it, you may return it unused by following our return procedure. Shipping charges are not refundable unless the return is a result of our error. Return freight charges are the responsibility of the buyer. Items must be returned in their original packaging.

All returns must be authorized. Product that has been used may not be returned. A 15% restocking fee will be assessed on returned merchandise to compensate for repackaging, warehousing and administrative labor. The return procedure is listed below. For specific questions relating to returns or warranty, please contact Customer Service department toll-free at 1-800-654-1704 or at custserv@realflame.com.

Step 1: Contact Customer Service department by phone or email to receive your Return Merchandise Authorization number (RMA#). The RMA# is necessary for all returns. Please indicate a reason for the return so we can better meet customer needs in future.

Step 2: Note your RMA# on the packing slip and repack the item in the original packaging. Be sure to include your packing slip with the returned product.

Step 3: Include your RMA# on the outside of the box and ship the package back to us via common carrier. Please provide us with the tracking number for your shipment.

Step 4: We will contact you when the package has been received and inspected. Provided a satisfactory return, we will credit your account for the returned merchandise less the applicable restocking charges.

Customer Service:
1-800-654-1704 or
custserv@realflame.com